

INSTRUCTION SHEET

MM3 SERIES MONITOR MOUNT

MM3-2X2BLK

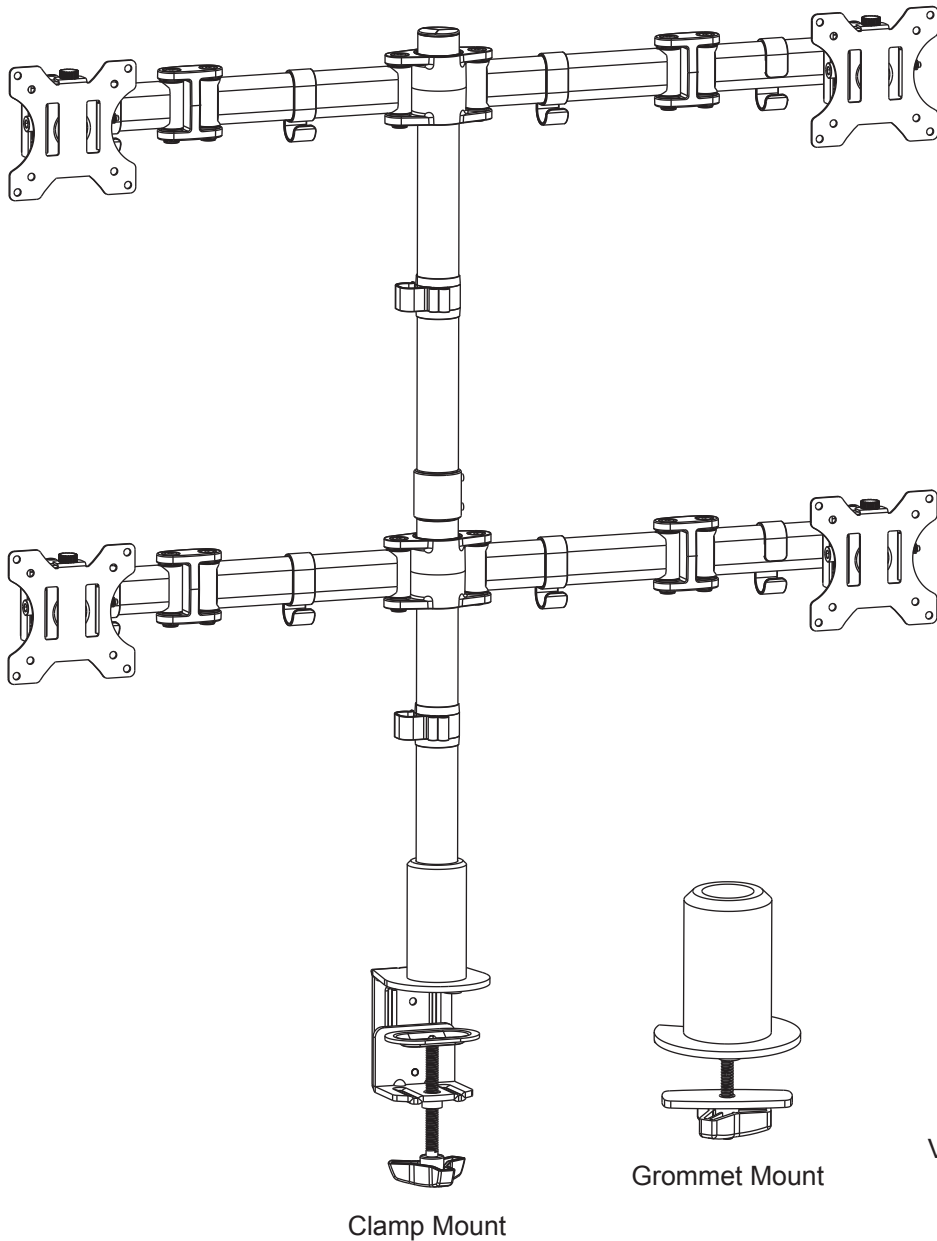

THANK YOU

Thank you for purchasing the MM3-2X2BLK monitor mount. Please read these instructions thoroughly before installing or assembling this product.

PRODUCT FEATURES

- Accepts up to (4) 27" Monitors
- Weight Capacity = 17.6 lbs. per monitor (4x) = 70.4 lbs.

IMPORTANT SAFETY INSTRUCTIONS

- Read these instructions.
- Heed all warnings.
- Clean only with dry cloth.
- Keep these instructions.
- Follow all instructions.
- Only use attachments/accessories specified by the manufacturer.



DANGER HAZARDOUS VOLTAGE: The lightning flash with the arrowhead symbol, within an equilateral triangle is intended to alert the user to the presence of uninsulated dangerous voltage within the product's enclosure that may be of sufficient magnitude to constitute a risk of electric shock to persons.



WARNING: A warning alerts you to a situation that could result in serious personal injury or death.



CAUTION: A caution alerts you to a situation that may result in minor personal injury or damage to the product and/or property.

NOTE: A note is used to highlight procedures pertaining to the installation, operation, or maintenance of the product.



WARNING: Failure to read, understand and follow the following information can result in serious personal injury, damage to the equipment or voiding of the warranty. It is the responsibility of the Installer/User to ensure that this product is loaded according to specifications.



WARNING: Exceeding the weight capacity may result in personal injury or equipment damage. The combined weight of all components attached to the mount must not exceed weights listed on page 3.



WARNING: Death or serious injury may occur when children climb on audio and/or video equipment furniture. A remote control or toys placed on the furnishing may encourage a child to climb on the furnishing and as a result the furnishing may tip over on the child.



WARNING: Relocating audio and/or video equipment to furniture not specifically designed to support audio and/or video equipment may result in death or serious injury due to the furnishing collapsing or over turning onto a child.



WARNING: Be aware of pinch points and do not place fingers in between moving parts.



WARNING: Use this product for its intended use and only use attachments recommended by the manufacturer.



WARNING: Do not use a damaged product. Return damaged products to a qualified service center for repair.



WARNING: Not intended for outdoor use.

INSTRUCTIONS IMPORTANTES SUR LA SÉCURITÉ

- Lire ces instructions.
- Respectez tous les avertissements.
- Nettoyer uniquement avec un chiffon sec.
- Conservez ces instructions.
- Suivez toutes les instructions.
- N'utilisez que des accessoires spécifiés par le fabricant.



DANGER TENSION DANGEREUSE: Le symbole de la pointe de flèche, dans un triangle équilatéral, est destiné à alerter l'utilisateur sur la présence de tension dangereuse non isolée dans l'enceinte du produit qui peut être d'une ampleur suffisante pour constituer un risque d'électrocution.



AVERTISSEMENT: Un avertissement vous avertit d'une situation pouvant entraîner des blessures graves ou la mort.



ATTENTION: Une attention vous avertit d'une situation pouvant entraîner des blessures mineures ou des dommages au produit et/ou à la propriété.

REMARQUE: Une remarque est utilisée pour mettre en évidence les procédures relatives à l'installation, au fonctionnement ou à l'entretien du produit.



AVERTISSEMENT: Refus de lire, comprendre et suivre la renseignements suivants peut traduire par de graves blessures, des dommages à l'équipement ou invalider la garantie. Il est la responsabilité de l'installateur / utilisateur de s'assurer que ce produit est chargé conformément aux spécifications.



AVERTISSEMENT: Dépassez la capacité de poids peut entraîner des blessures ou des dommages matériels. Le poids combiné de tous les composants reliés au support de montage ne doit pas dépasser les grammages indiqués à la page 3.



AVERTISSEMENT: Des blessures graves ou mortelles peuvent survenir si un enfant grimpe sur le meuble d'un équipement audio ou vidéo. Une télécommande ou un jouet placé sur le meuble peut encourager un enfant à grimper dessus et conduire à la chute du meuble sur ce dernier.



AVERTISSEMENT: Le transfert d'un équipement audio ou vidéo sur un meuble qui n'a pas été spécialement conçu pour soutenir un équipement audio ou vidéo peut entraîner l'effondrement ou le basculement du meuble sur un enfant et provoquer des blessures graves ou mortelles.



AVERTISSEMENT: Soyez conscient des points de pincement et de ne pas placer les doigts entre les pièces mobiles.



AVERTISSEMENT: Utilisez ce produit pour son utilisation prévue et utiliser uniquement les accessoires recommandés par le fabricant.



AVERTISSEMENT: Ne pas utiliser un produit endommagé. Retour produits endommagés à un centre de service qualifié pour la réparation.



AVERTISSEMENT: Non destiné à une utilisation en extérieur.

WEIGHT RATINGS

Model	Weight Rating
MM3-1X2BLK	17.6 lbs. per monitor (4x) = 70.4lbs.

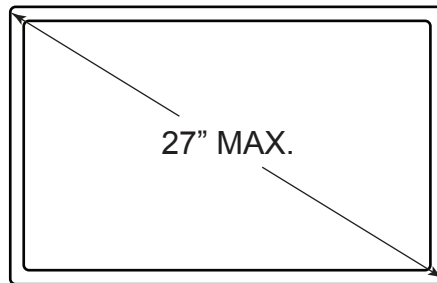

SUPPLIED COMPONENTS AND HARDWARE

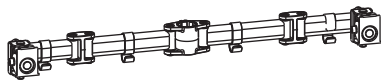

(2x)
Arm Assembly
A

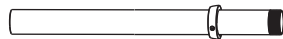

Pole
B

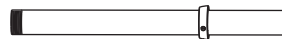

Extension Pole
C

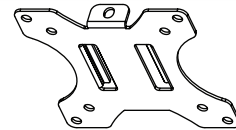

(4x)
Display Mount
Bracket
D



Adapter Plate
E

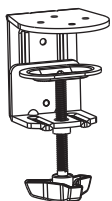

Clamp
Assembly
F

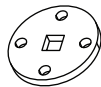

Cup Mount
Plate
G

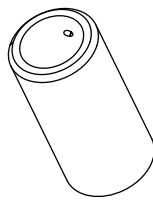

Pole
Base
H



(4x)
Plate
Screw
J



Pole
Coupler
K

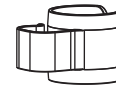

(2x)
Cable Management
Clip
L



Grommet
Plate
M



(4x)
Flat Head
Screw
N



Short
Carriage
Bolt
P



Long
Carriage
Bolt
R



(5x)
Adhesive Pad
S



Knob
T



6mm Hex Key
U



5mm Hex Key
V



4mm Hex Key
W



3mm Hex Key/
L-Type
Screwdriver
X

MONITOR HARDWARE



(16x)
M4x12 Pan
Head Screw
M-A



(16x)
M4x16 Pan
Head Screw
M-B



(16x)
M5x12 Pan
Head Screw
M-C

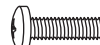

(16x)
M5x16 Pan
Head Screw
M-D



(16x)
Washer
M-E



(16x)
Spacer
M-F

NOTE: Additional hardware is included that may not be required for your installation.

REQUIRED TOOLS

- #2 Phillips Head Screwdriver
- #4 Slotted Screwdriver
- Standard Socket Set
- 5/16" Socket



WARNING: Use tools with caution and follow all necessary safety protocols.

AVERTISSEMENT: Utiliser des outils avec prudence et suivre tous les protocoles de sécurité nécessaires.

MOUNTING THE BASE

GROMMET MOUNTING

1. Insert carriage bolt (R) through adapter plate (E) as shown. (**FIGURE A**)
2. Attach adapter plate (E) to pole base (H) using (4x) flat head screws (N) and tighten using 4mm hex key (W) as shown.
3. Apply (4x) adhesive pads (S) around the bottom of adapter plate (E) evenly spaced.
4. Insert pole base assembly into grommet hole in work surface. Using grommet plate (M) and knob (T), tighten base securely to work surface.

NOTE: If using grommet hole for wire management, position assembly with cutout in line with wires before tightening assembly in place.

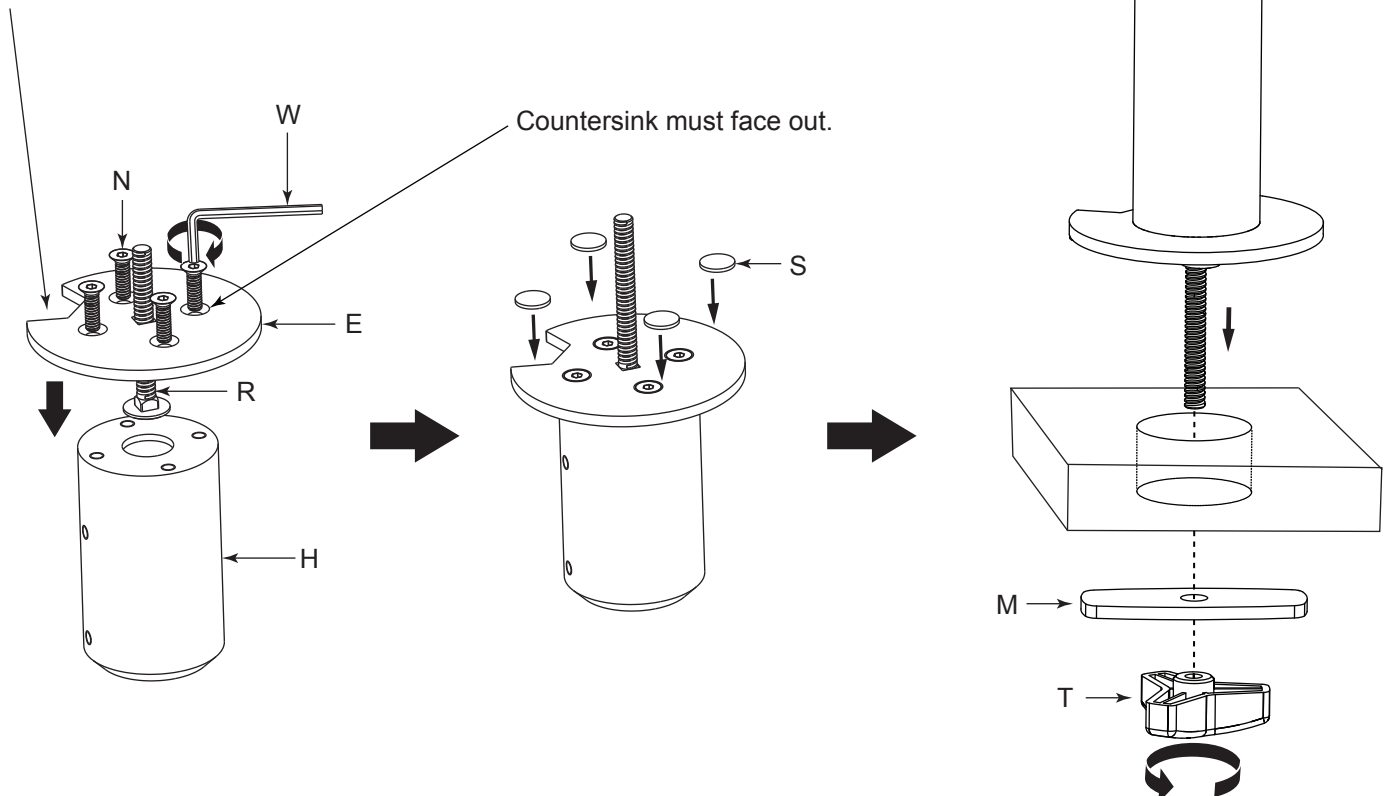

FIGURE A

MOUNTING THE BASE (CONTINUED)

CLAMP MOUNTING

1. Attach pole base (H) to clamp assembly (F) using (4x) flat head screws (N) and tighten using 4mm hex key (W) as shown. **(FIGURE B)**
2. Apply (4x) adhesive pads (S) around the bottom of clamp assembly (F) evenly spaced.
3. Slide assembly over work surface and tighten securely in place.

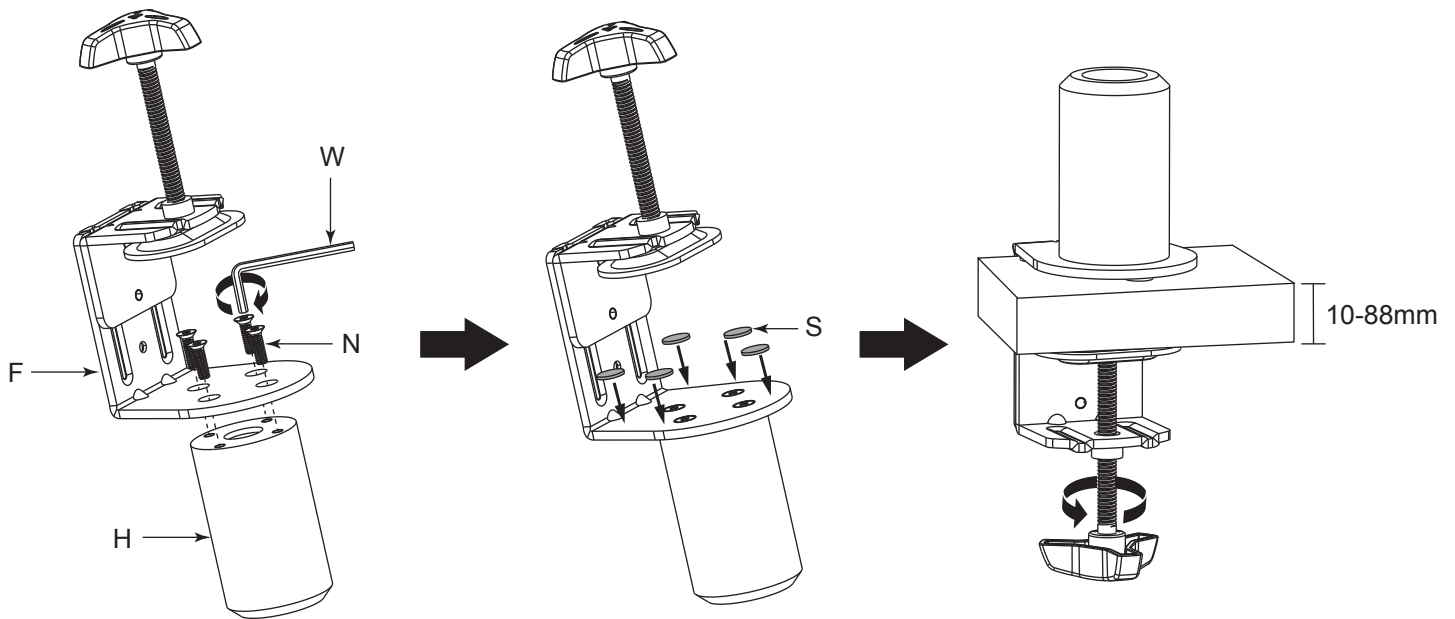

FIGURE B

MOUNTING THE BASE (CONTINUED)

VIEWPOINT CONSOLE MOUNTING

1. Insert short carriage bolt (P) into cup mount plate (G) as shown. (**FIGURE C**)
2. Attach cup mount plate (G) to pole base (H) using (4x) flat head screws (N) and tighten using 4mm hex key (W) as shown.
3. Apply (4x) adhesive pads (S) over each screw head.
4. Select the mount location along the back of the ViewPoint console frame and remove protective dustcap nearest to your desired mount position. Thread the base assembly into frame tightening base down securely.

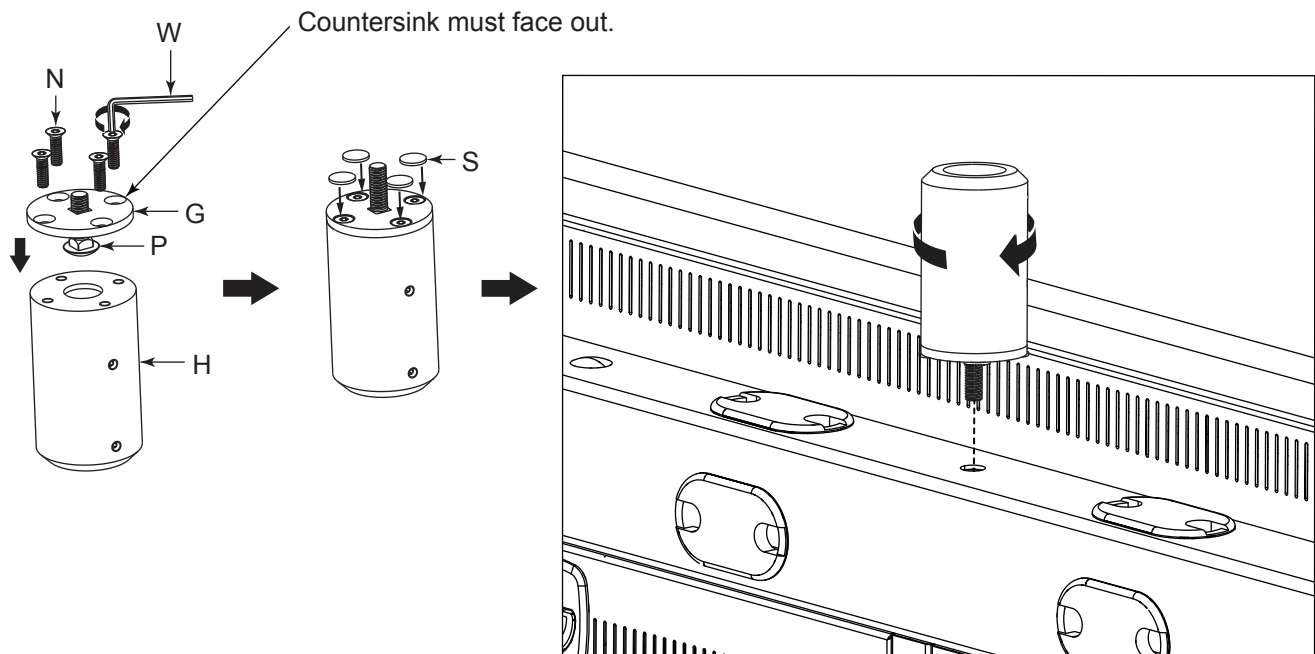

FIGURE C

ASSEMBLING POLE TO BASE

1. Slide cable management clip (L) onto pole (B) as shown. (FIGURE D)
2. Loosen set screws in pole base (H) and push onto pole (B) until it bottoms out.
3. Using 3mm hex key (X), tighten set screws to lock pole onto base.
4. To adjust height of arm support ring, loosen set screw with L-type screwdriver (X).

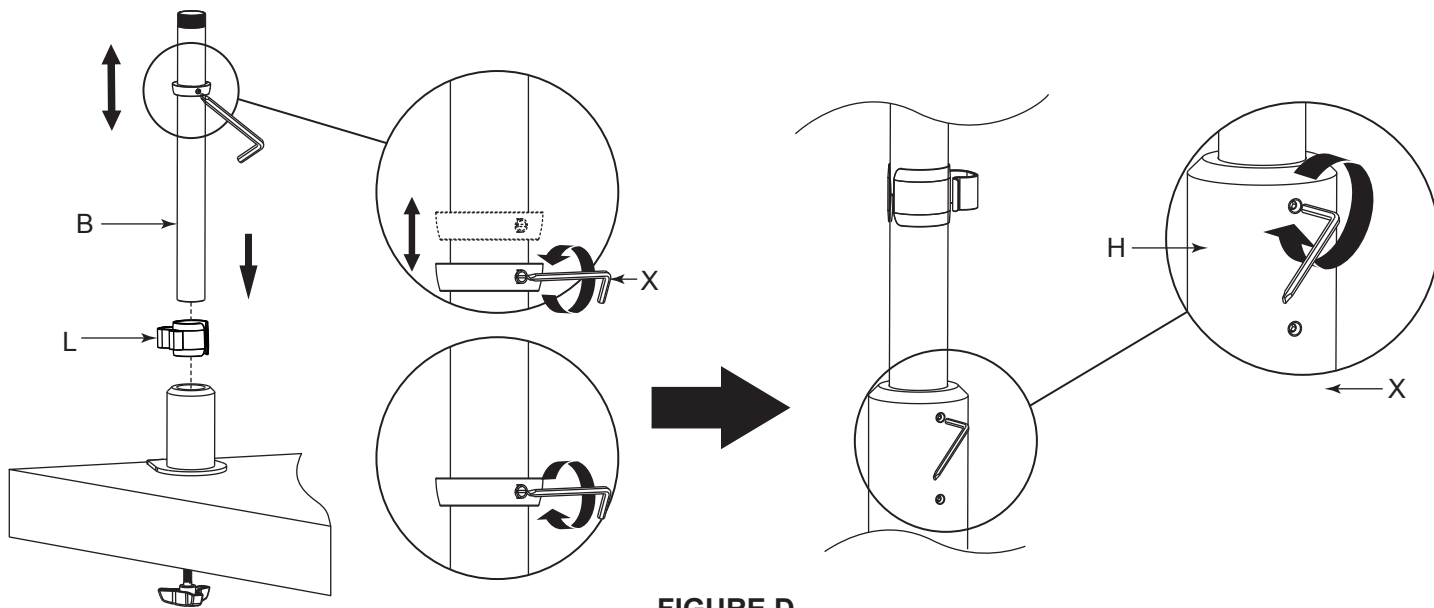

FIGURE D

MOUNT ASSEMBLY

1. Slide arm assembly (A) onto pole (B) as shown. (FIGURE E)
2. Slide arm assembly on top of height adjustment ring and tighten clamp screw to secure using 5mm hex key (V).

NOTE: If arm height is not known at this point, ring and assembly can be moved by loosening the clamp screw and arm height adjustment ring set screw.

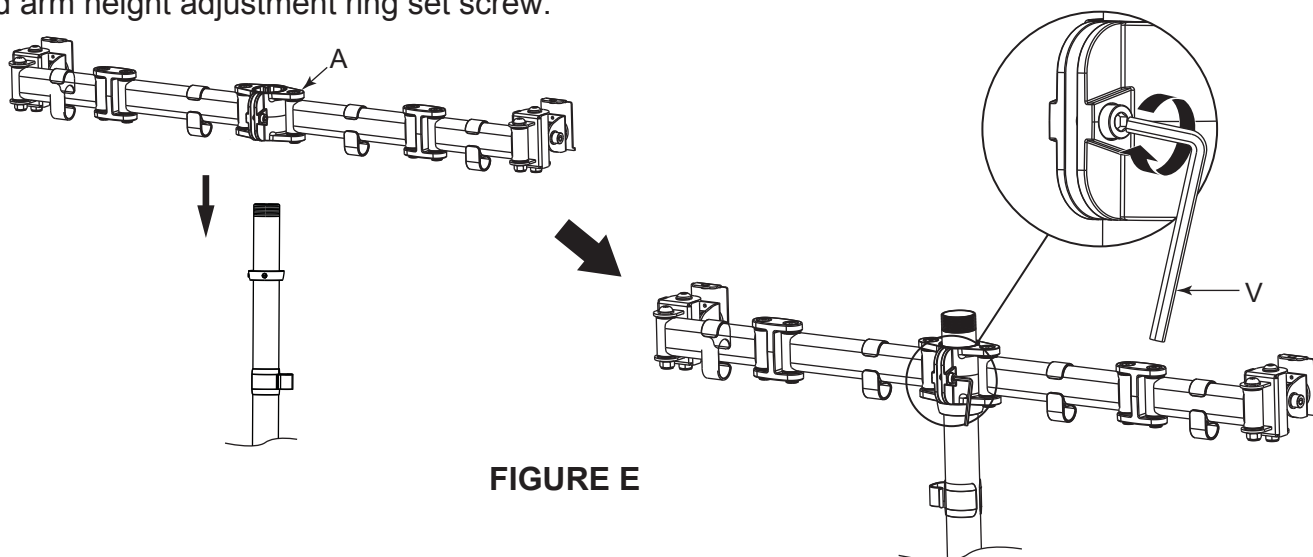

FIGURE E

ASSEMBLING POLE TO BASE (CONTINUED)

1. Thread pole coupler (K) onto pole (B) as shown. **(FIGURE F)**
2. Thread extension pole (C) into coupler (K).
3. Using 3mm hex key (X), tighten set screws to secure poles from turning.

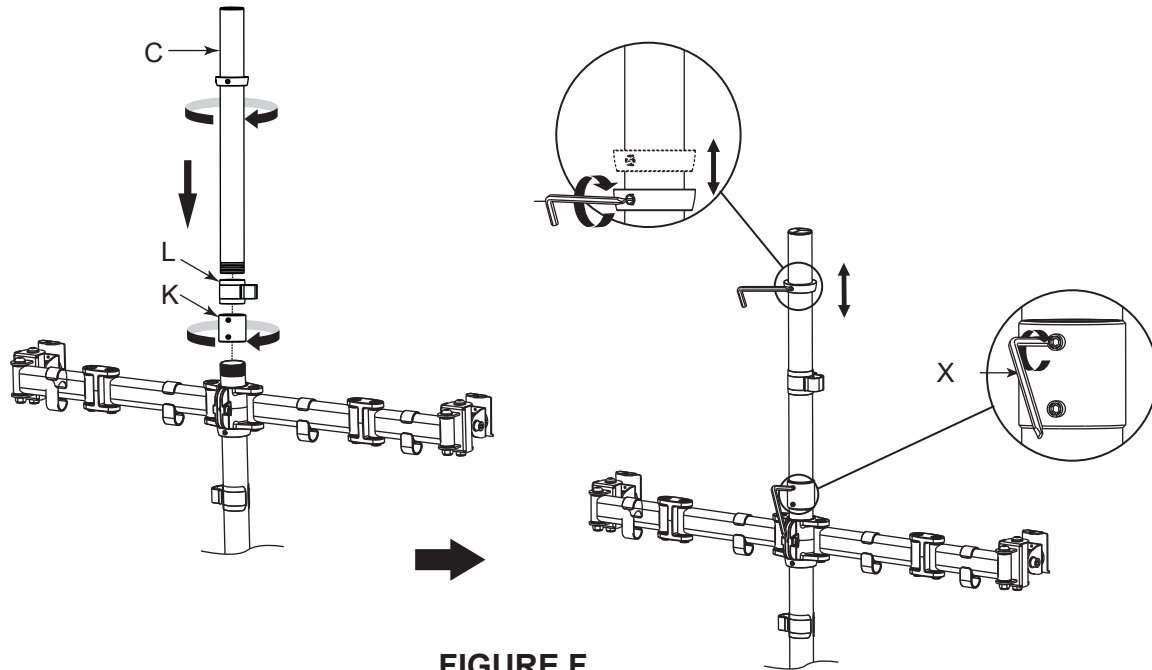

FIGURE F

4. Slide cable management clip (L) onto extension pole as shown. **(FIGURE G)**
5. Slide arm assembly (A) onto extension pole (C) as shown.
6. Slide arm assembly on top of height adjustment ring and tighten clamp screw to secure using 5mm hex key (V).

NOTE: If arm height is not known at this point, ring and assembly can be moved by loosening the clamp screw and arm height adjustment ring set screw.

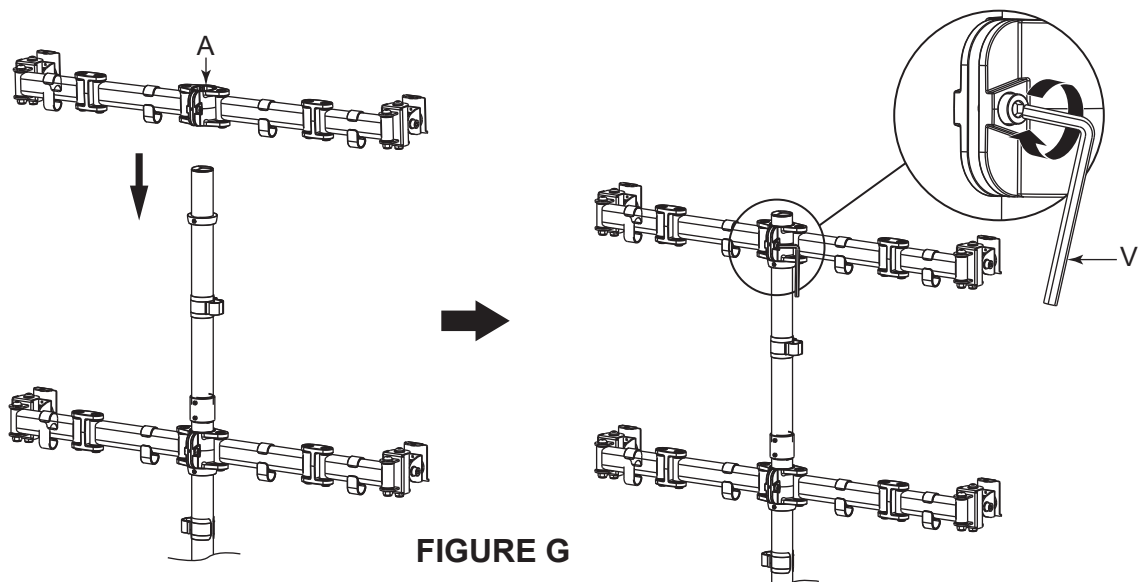

FIGURE G

FLUSH DISPLAY MOUNT BRACKET INSTALLATION

1. Using supplied display mount screws, select the appropriate screw size and length ensuring screw does not bottom out in mounting hole, or damage to display may occur.

NOTE: If you feel resistance, stop immediately and try a shorter screw. If supplied screws are still too long, use supplied spacers to take up slack.

2. Align display mount bracket (D) with mounting holes on the back of display. Use (4x) display mount screws (M-A - M-D) and (4x) washers (M-E) to secure the display mount brackets to your display.
(FIGURE H)

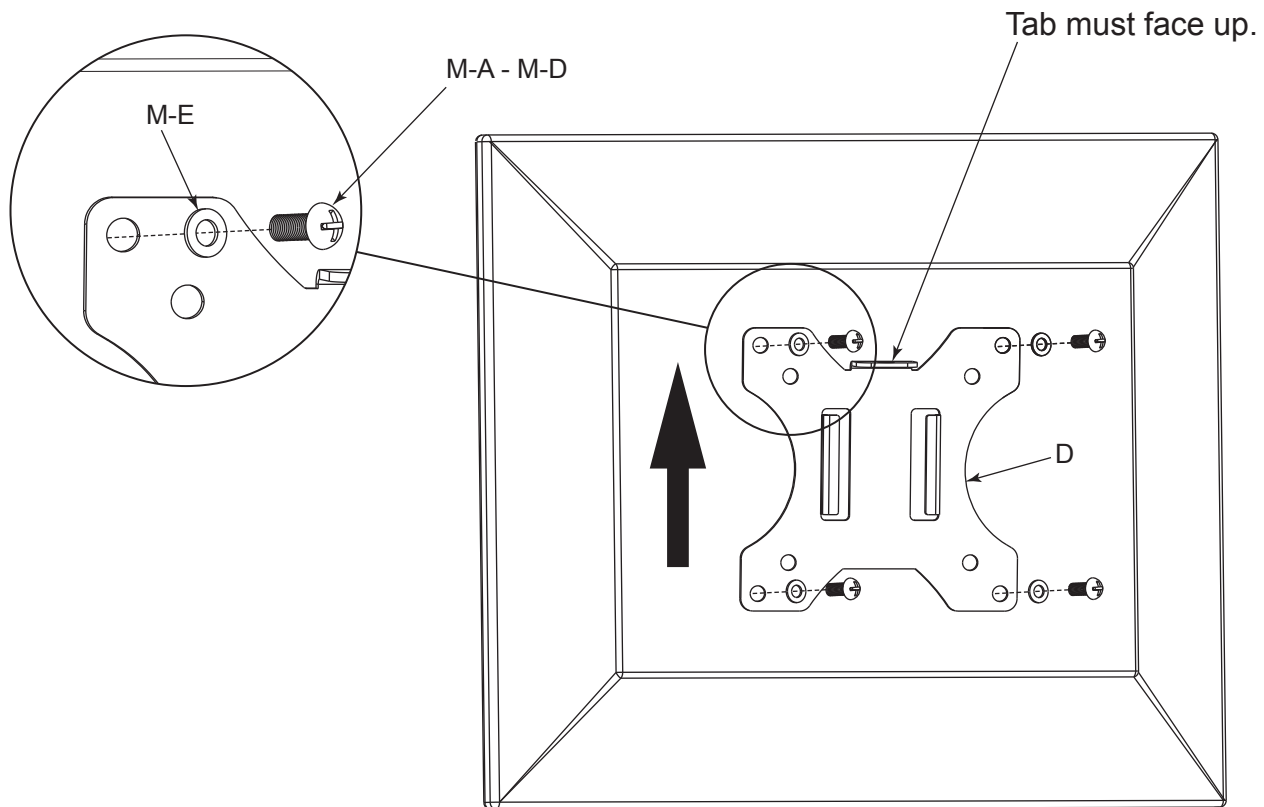

FIGURE H

RECESSED OR RAISED BACK DISPLAY MOUNT BRACKET INSTALLATION

1. Using supplied display mount screws, select the appropriate screw size and length ensuring screw does not bottom out in mounting hole, or damage to display may occur.

NOTE: If you feel resistance, stop immediately and try a shorter screw. If supplied screws are still too long, use supplied spacers to take up slack.

2. Align display mount bracket (D) with mounting holes on the back of display. Use (4x) display mount screws (M-A - M-D), (4x) washers (M-E), and (4x) spacers (M-F) to secure the display mount brackets to your display. (**FIGURE J**)

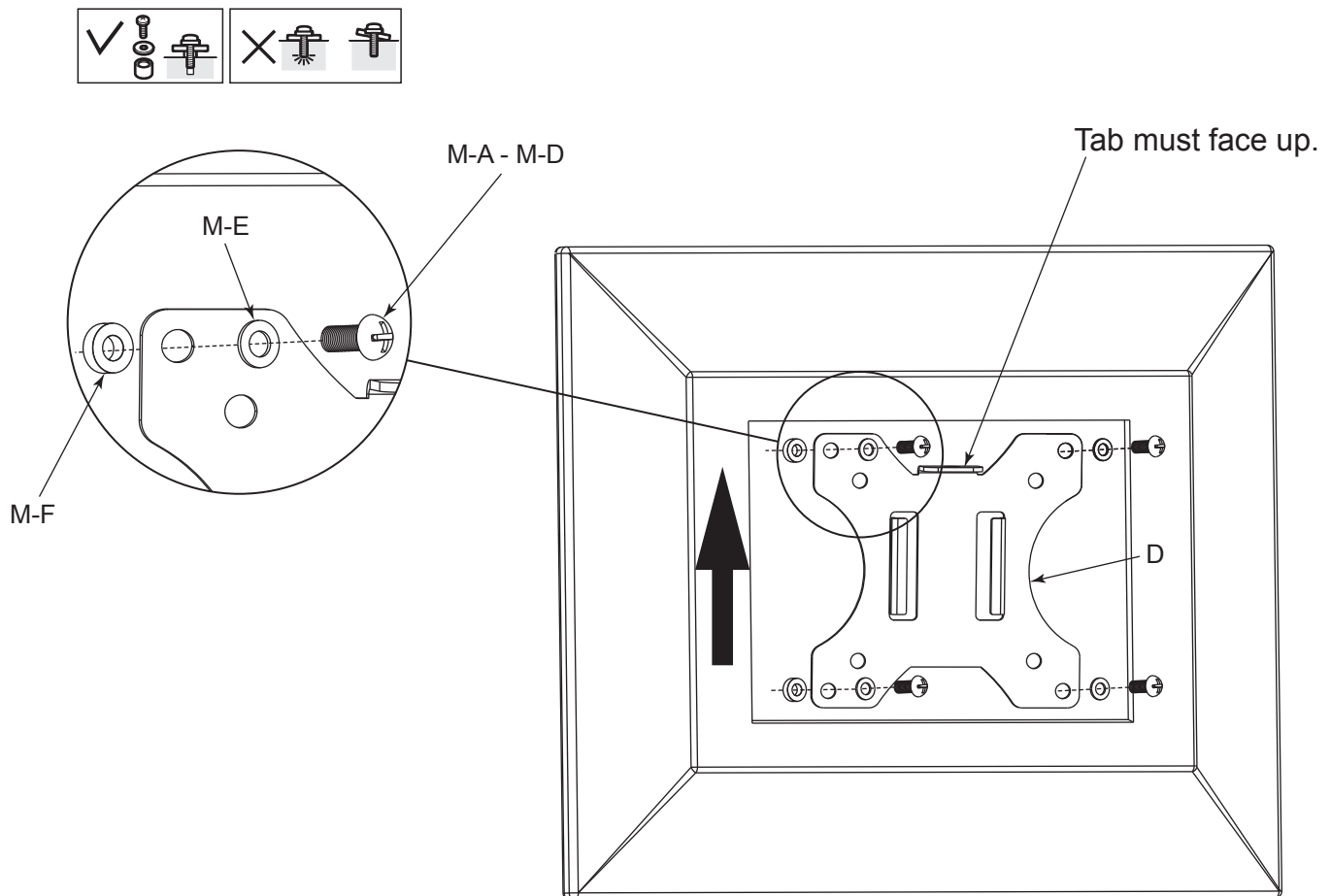

FIGURE J

MONITOR INSTALLATION

1. With monitor attached, slide display mount hooks onto arm assembly knuckle plate as shown. Repeat for second monitor. **(FIGURE K)**
2. Using (2x) thumb screws (J), secure display mount to each arm assembly.

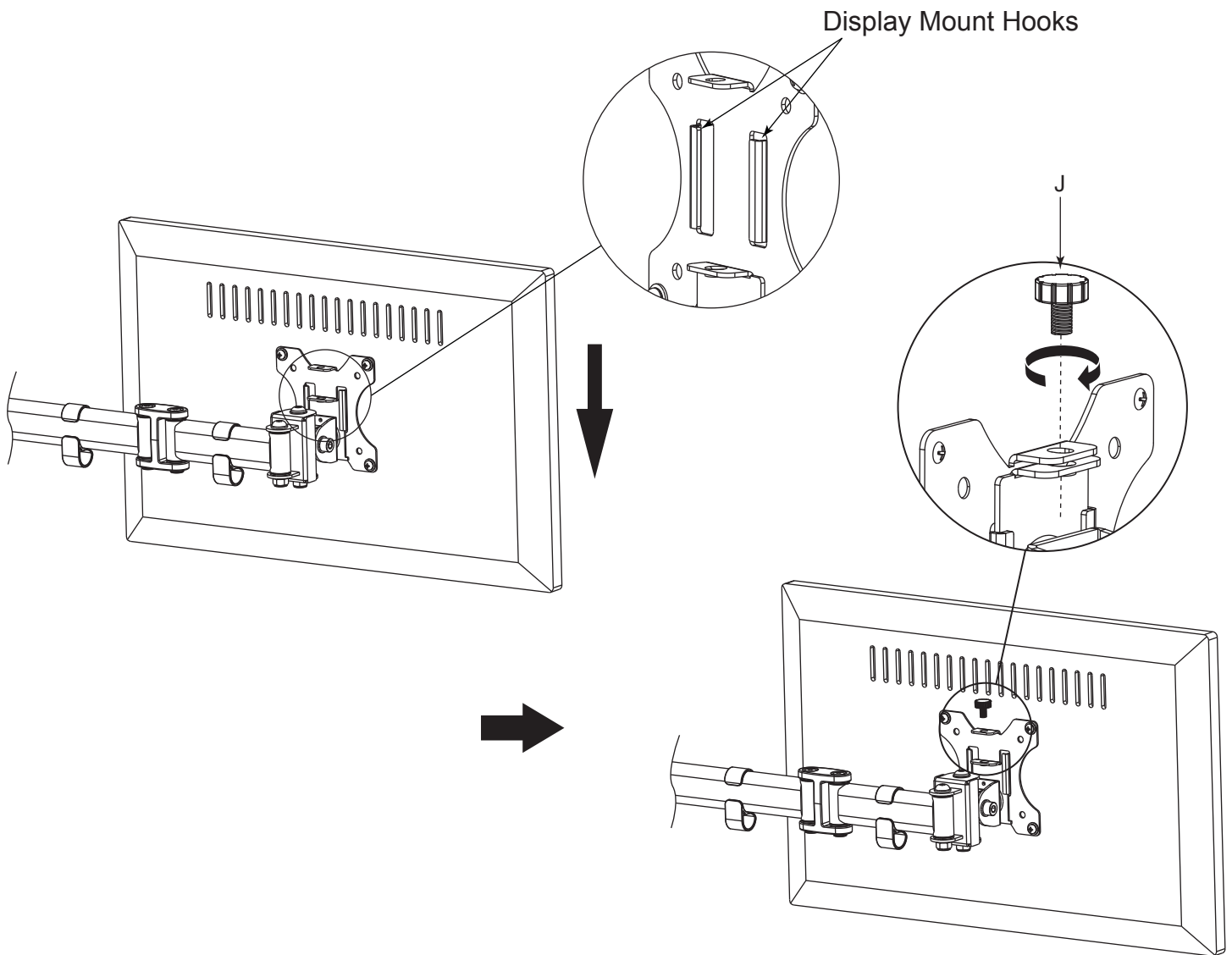

FIGURE K

ADJUSTMENT AND CABLE MANAGEMENT

1. To adjust display angle, loosen socket cap screws on the side of the monitor mount knuckle using 6mm hex key (U) and retighten when desired angle is set. **(FIGURE L)**

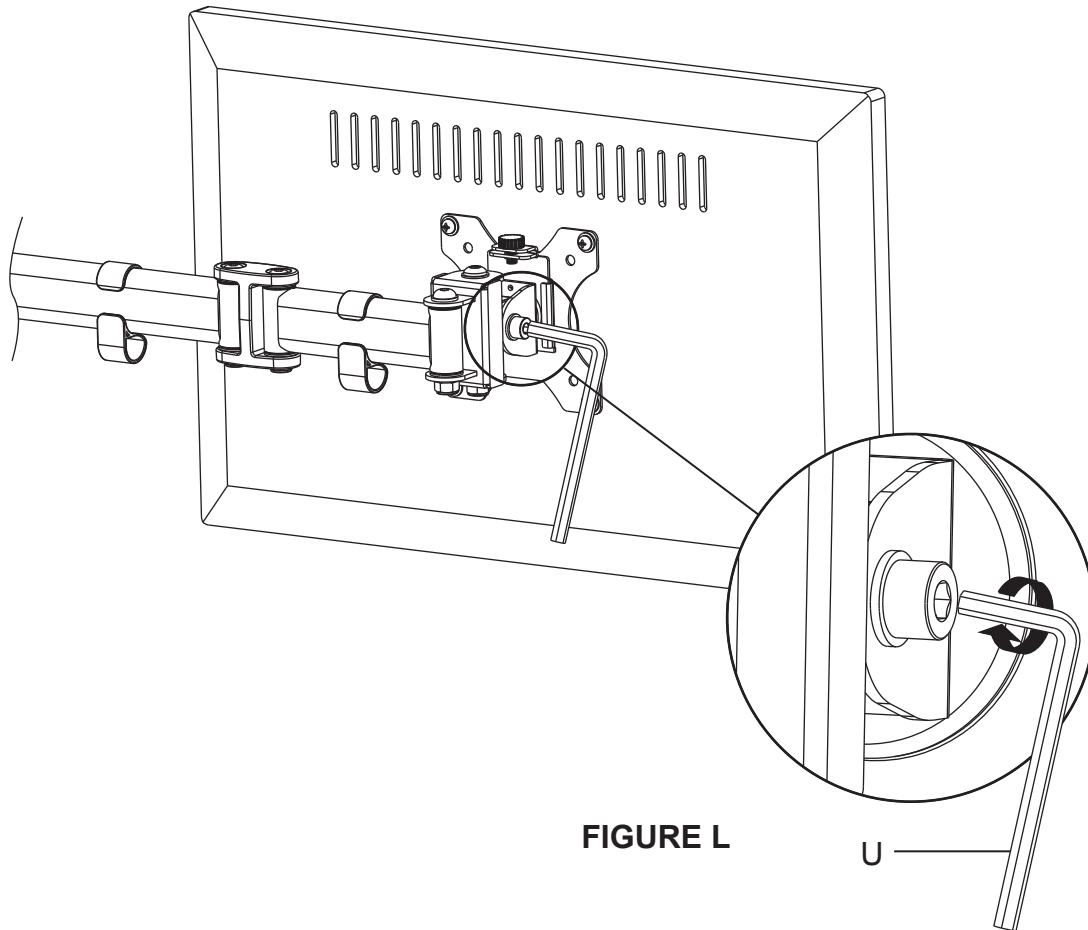

FIGURE L

2. Route cables through cable management clip (L). **(FIGURE M)**

NOTE: Cable management clip provides storage for supplied hex keys for future adjustment.

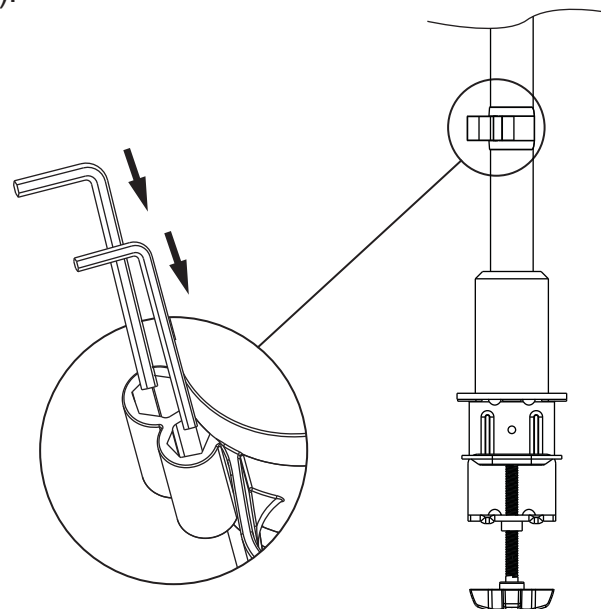

FIGURE M

ADJUSTMENT AND CABLE MANAGEMENT (CONTINUED)

1. To micro-adjust monitor heights, rotate button head screw on top of arm knuckle to raise or lower each monitor for alignment using 5mm hex key (V). (**FIGURE J**)

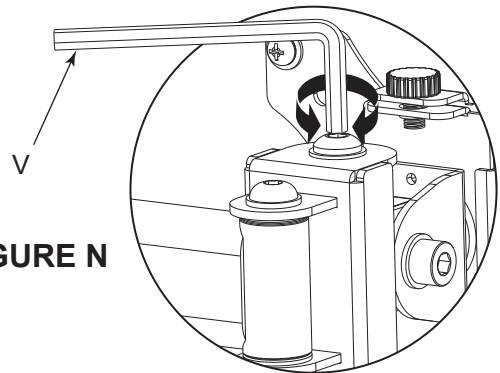
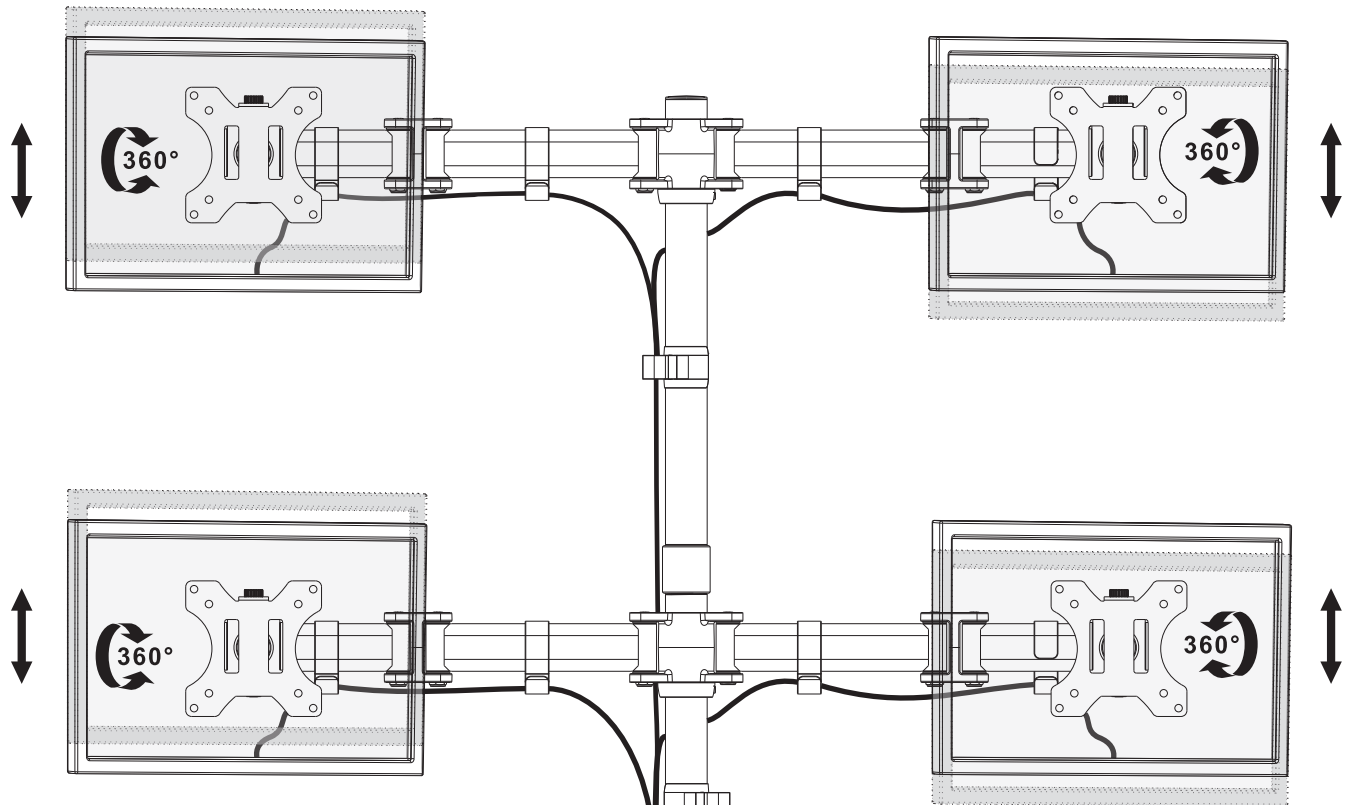

FIGURE N



NOTE: When installed in a grommet hole, slot in adapter plate can be used to feed cables through grommet hole. (**FIGURE P**)

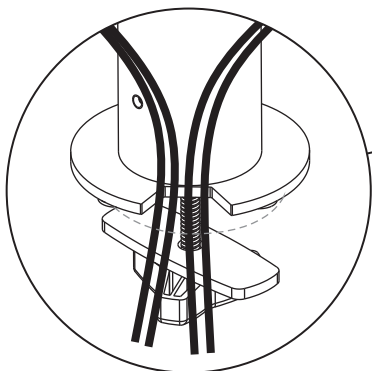

FIGURE P

WARRANTY

For warranty information, refer to <http://www.middleatlantic.com/company/about-us.aspx#warranty>

Corporate Headquarters

Corporate Voice: 973-839-1011 - Fax: 973-839-1976 / International Voice: +1 973-839-8821 -
Fax: +1 973-839-4982
www.middleatlantic.com - info@middleatlantic.com

Middle Atlantic Canada

Voice: 613-836-2501 - Fax: 613-836-2690 / ca.middleatlantic.com -
customerservicecanada@middleatlantic.ca

Factory Distribution

USA: NJ - CA - IL Canada: ON - BC

At Middle Atlantic Products we are always listening. Your comments are welcome.

Middle Atlantic Products is an ISO 9001 and ISO 14001 Registered Company.



Middle Atlantic Products

what great systems are built on™

middleatlantic.com ■ 800.266.7225